

MULLING VINYLLOCK[®] DOUBLE HUNG REPLACEMENT WINDOWS UTILIZING A SNAP MULLION

PLACE SCREW AT JAMB SILL SECTION INTO
FACTORY PREPUNCHED INSTALLATION HOLES

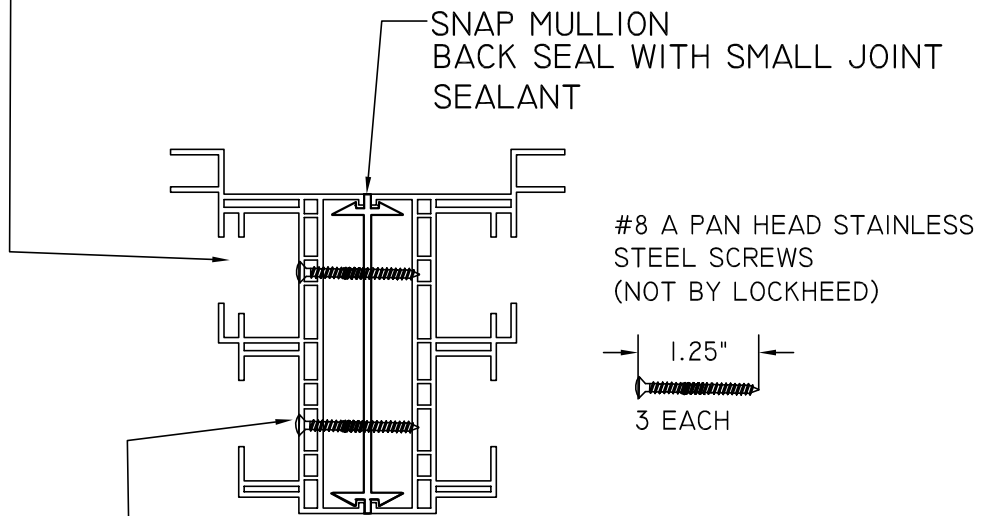

PLACE SCREW AT JAMB HEAD SECTION INTO FACTORY
PREPUNCHED INSTALLATION HOLE

REMOVE WAFER HEAD JAMB ADJUSTER FROM EACH MULLED JAMB
AND PLACE SCREW INTO FACTORY PREPUNCHED HOLE

THERE SHOULD BE A TOTAL OF THREE SCREWS PER MULLION ASSEMBLY

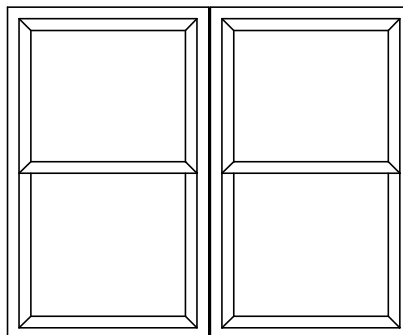

ONE AT JAMB HEAD
ONE AT JAMB MIDPOINT
ONE AT JAMB SILL

NOT TO SCALE

LOCKHEED

WINDOW CORP.

Route 100, Pascoag, Rhode Island 02859

TEL: (401) 568-3061

FAX: (401) 568-2273

www.lockheedwindow.com

Form #690
Revised 5/06